

R21™ *Powered Raceway*

R21 Powered Raceway from Strand Lighting is a perfect extension of our C21 and A21 range of installed dimmer cabinets. Systems can be mixed and matched as needed to create a completely flexible lighting system to meet the needs of any installation. Our powered raceway features quiet convection cooled IGBT dimming for low lamp noise and reliable operation.

Strand Lighting's powerful ShowNet Ethernet network allows easy integration of your entire lighting system

with consoles, houselight systems and portable and fixed dimming racks all connecting seamlessly over a network. The heart of the system is our powerful Raceway processor may be mounted locally on the raceway or remotely in an easy to access auxiliary rack. One processor can control up to 96 dimmers over multiple raceways simplifying set up and operation. Our Guardian software allows remote configuration and status monitoring over our network as well.

Each raceway can have dimmed circuits for conventional luminaires and constant power for automated lighting systems. A wide range of hangers are available for pipe mount and wall mount applications to meet the needs of any installation.

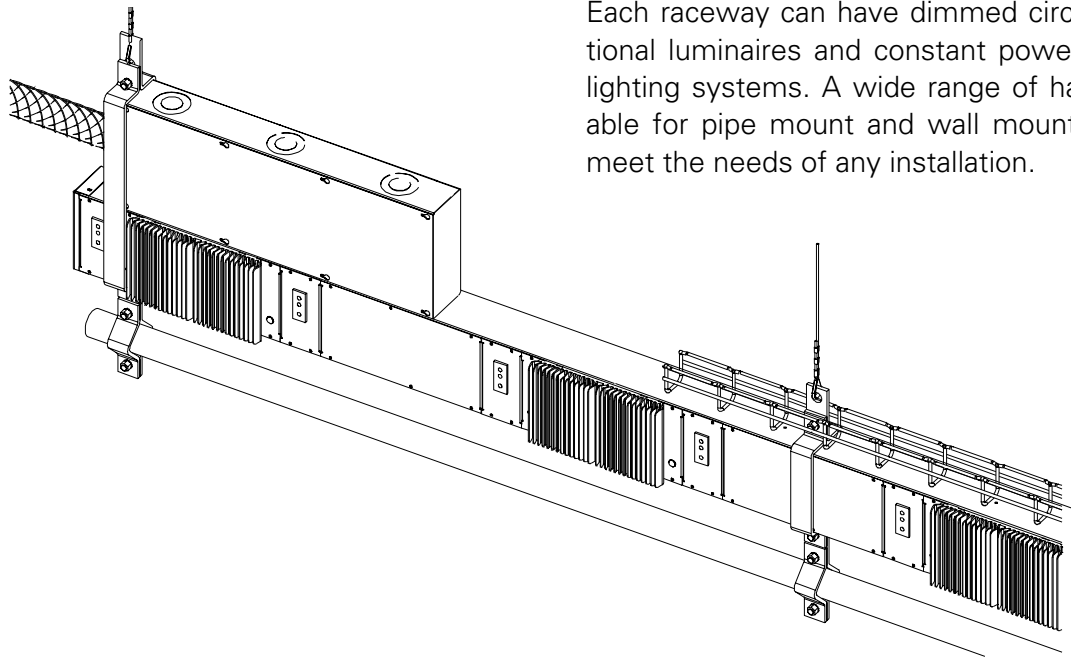

Features

- Fully Digital Powered Raceway
- DMX 512 I/O
- Simplified Data distribution over ShowNet Networking
- Remote processor option provides support for up to 96 dimmers
- Quiet convection cooled dual IGBT dimmers
- Energy efficient –only a 2.5 volt insertion loss
- Local Focus buttons and status display
- 800 μ s transition time significantly reduces lamp sing
- Automatic Short Circuit protection
- Wide range of load connector options
- Integrates with Strand C21 and A21 Dimmers
- Dimmer Status reporting standard
- Hangers available for Wall and pipe mount applications
- UL, cUL listed

Ordering Information

Cat No Description

R21 Powered Raceway

96350-xxxx aa= Length in feet
 bb= 20 amp dual dimmer modules
 cc= Flush or Pigtail connectors and type
 dd= mounting hardware

Mounting hardware

71440 Single Pipe Hanger
 71441 Double Pipe Hanger
 71442 Wall Mount
 71443 Double Pipe Hanger Offset Mounting
 71444 Overhung pipe hanger
 71445 Single Pipe Hanger Threaded Rod

Technical Information

Number of dimmers	up to 96	Height	6" (14.5" with terminal box)
Max Output voltage	115./120 volts	Depth	5.25" including module heatsink
Minimum load	1watt	Length	8 to 96 feet
Maximum load per dimmer pair	2400 watts	Weight	6.5 lbs per foot
Insert loss	Max 2.5 volts	Connector Types	GP – Grounded Stage Pin (flush or pigtail mounting)
Power feed amps per 3 modules	3-phase 4 wire 120/208 volts 20		GTL – Twistlock (flush or pigtail mounting)
Frequency	50/60Hz		GR – Edison NEMA 5-20R
Ambient temperature	0-40 degrees C		
Humidity	5%-95% Non condensing		
Cooling	Convection		

Strand Lighting, Inc.
 6603 Darin Way, Cypress, CA 90630, USA
 Tel: +1 714 230 8200
 Fax: +1 714 230 8173

Strand Lighting Asia
 20/F Delta House, 3 On Yiu Street
 Shatin, N.T. Hong Kong
 Tel: + 852 2757 3033
 Fax: + 852 2757 1767

