



100 Series Control Console

Portable or Rack Mounting Control System

Features

- Fully digital control console
- 12 channel 2 scene preset, 24 channel single scene preset operation with unique Hold function in single scene mode
- Built in effect operation
- Designed for portable or rack mounting applications with removable end caps to facilitate rack mounting
- Split crossfader with time fade function
- Bump buttons
- Grand Master and Black out key
- DMX 512 output
- Available with 120 volt UL, cUL power supply or 230/240 volt CE marked supplies

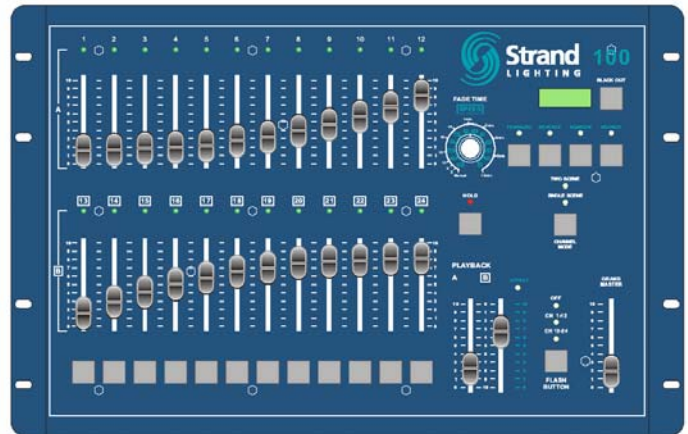

Ordering information

Cat No	Description
61312	100 series 12/24 console 120 volt
61313	100 series 12/24 console 230/240 volt

Mechanical Data

Weight: 2kg
 Finish: Blue powder coat epoxy paint
 Construction: Rigid folded sheet steel

Environmental Data

Temperature: 0-35°C
 Humidity Range: 0-90% non condensing
 Ingress Protection: IP 20

Standards Compliance

All units are CE marked 120 volt consoles include UL, cUL power supplies

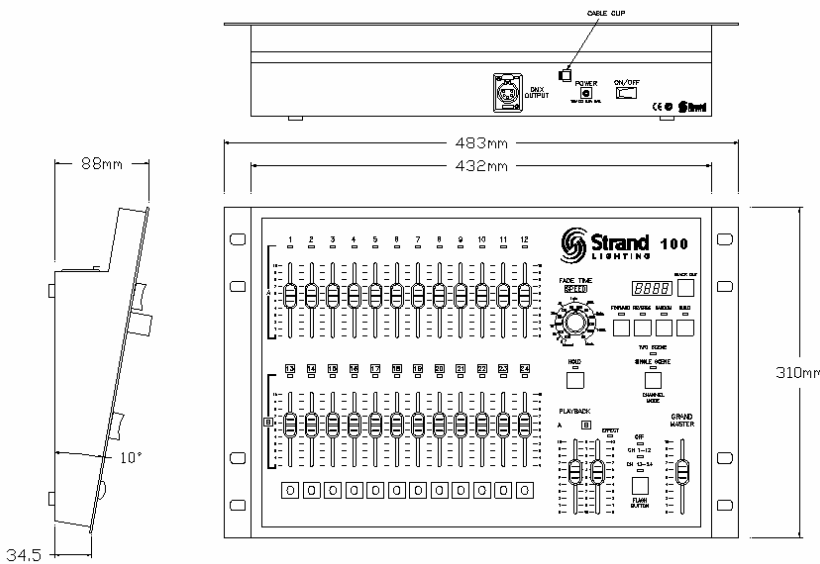

100 Series Control System



Strand Control Systems

Strand Lighting Inc
6603 Darin Way, Cypress, CA 90630, USA
Tel: +1 714 230 8200 Fax +1 714 230 8173

**Strand Lighting (Canada)
Inc/Eclairages Strand (Canada) Inc**
2430 Lucknow Drive No 15
Mississauga Ontario L5S 1V3 Canada
Tel: +1 905 677 7130 Fax: +1 905 677 6859



The Company reserves the right to make any variation in design or construction to the equipment described.
© Strand Lighting Ltd. 2002
Strand™, Strand Lighting™, Strand Quartzcolor™ are trademarks of Strand Lighting Limited and Strand Lighting Inc.

BERLIN • HONG KONG • LONDON • LOS ANGELES • MOSCOW • NEW YORK • PARIS • ROME • TORONTO

www.strandlighting.com